

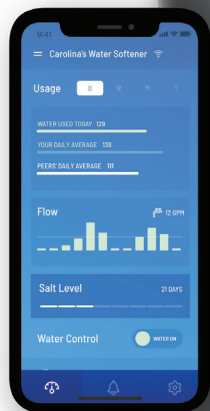

NORTH STAR[™]
WATER TREATMENT SYSTEMS



RESIDENTIAL WATER SOFTENER **GUIDE**



COMPACT CABINET MODELS

NSC22

22,000 Grain Water Softener



FEATURES

- Ideal for small to medium households
- High flow valve for optimal water pressure
- 6 ppm clear water (ferrous) iron removal
- Built-in tank light

NSC31

31,000 Grain Water Softener



FEATURES

- Ideal for medium to large households
- High flow valve for optimal water pressure
- 8 ppm clear water (ferrous) iron removal
- Built-in tank light

NSC42

42,000 Grain Water Softener



FEATURES

- Ideal for any sized household
- Ultra high flow valve for up to 1" plumbing delivers maximum water pressure
- 11 ppm clear water (ferrous) iron removal
- Premium electronic board displays average daily gallons, flow rate, salt level and more
- Built-in tank light

2-in-1 Softener + Whole Home Filtration With WiFi



FEATURES

- High capacity 2-in-1 system softens & filters water throughout the entire home
- Utilizes WiFi technology and the iQua™ Water Management App to send critical water alerts directly to your phone
- Conveniently manage your home's water from anywhere, any time
- The optional North Star Motorized Water Shut-Off Valve allows homeowners to turn off their water via the iQua™ App if a leak occurs
- Reduces chlorine taste and odor using carbon filtration
- No filters to replace
- AutoSense™ Technology provides significant salt & water savings

ALL NEW CABINET MODELS FEATURE

AutoSense™ Technology

Monitors your water usage to determine the optimal frequency of regeneration, maximizing efficiency while minimizing salt and water usage.

Low Salt Monitor

Indicates the softener is working efficiently and flashes when the softener is getting low on salt, allowing you a few days to refill the salt tank.

High Capacity Media

Our long-lasting softening resin has more hardness holding capacity than standard resins, allowing you to go longer between regenerations.

Installation Kit

Our softeners come with everything needed to hook up to 1" NPT plumbing, including a bypass valve.

CHOOSE THE WATER SOFTENER THAT'S **RIGHT FOR YOU**



SPECIFICATIONS	CABINET MODELS				TWO-TANK MODELS		
Model Number	NSC22	NSC31	NSC42	NSCWHC	NST30ED	NST45ED1	NST70ED1
Part Number	NSC2218	NSC3118	NSC4218	NSCWHC1	7366431	7366449	7366457
Household Size	1-4	1-5+	All	All	1-5+	1-6+	All
Max Capacity (Grains)	22,100	31,300	42,100	31,100	30,200	45,300	70,000
Resin (cu. ft.)	0.65	0.81	1.20	0.98	0.78	1.26	1.94
Activated Carbon	No	No	No	Yes	No	No	No
Standard Connection Size	1" NPT	1" NPT	1" NPT	1" NPT	1" NPT	1" NPT	1" NPT
Valve	3/4"	3/4"	1"	1"	3/4"	1"	1"
Rated Service Flow Rate (gpm)	7.2	7.2	9.9	8.0	7.3	10.0	13.5
Intermittent Flow Rate (gpm @ 30 psi drop)	11.3	11.8	17.8	17.8	11.0	18.6	21.0
Clear Water Iron Removal (ppm)	6	8	11	3	8	12	19
Electronic Demand	Yes	Yes	Yes	Yes	Yes	Yes	Yes
Maximum Efficiency (grains removed per lb of salt)	4,474	5,090	4,940	4,780	5,090	5,070	5,080

DIMENSIONS

Dimension A	47.75"	47.75"	48"	48"	48.75"	50"	65.75"
Dimension B	41.5"	41.5"	41.5"	41.5"	41.25"	41.25"	57"
Dimension C	16.5"	16.5"	17"	17"	8.25"	10.5"	12.25"
Dimension D	19.75"	19.75"	21"	21"	11.5"	14"	14"
Dimension E	3.375"	3.375"	3.75"	3.75"	3.375"	3.75"	3.75"

WARRANTY

1 year on complete unit | **3 years** on electronic control board and valve body | **10 years** on salt storage tank and mineral tank

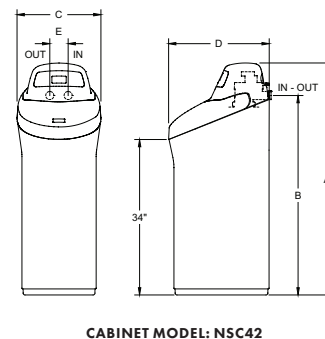
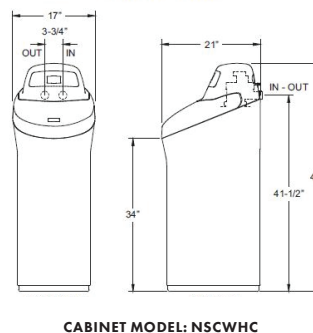
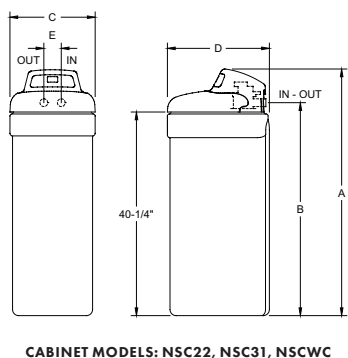
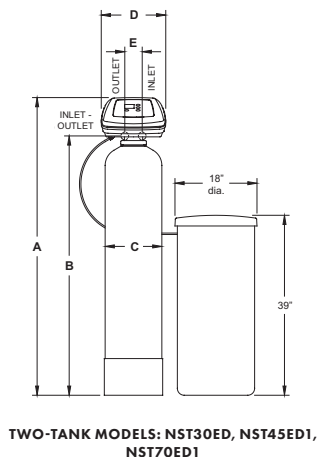

DURABLE TWO-TANK MODELS

NST30ED

30,000 Grain Water Softener



FEATURES

- Ideal for small to medium households
- High flow valve for optimal water pressure
- 8 ppm clear water (ferrous) iron removal

NST45ED1

45,000 Grain Water Softener



FEATURES

- Ideal for any sized household
- Ultra high flow valve for up to 1" plumbing delivers maximum water pressure
- 12 ppm clear water (ferrous) iron removal

NST70ED1

70,000 Grain Water Softener



FEATURES

- Ideal for any sized household
- Ultra high flow valve for up to 1" plumbing delivers maximum water pressure
- 19 ppm clear water (ferrous) iron removal

ALL TWO-TANK MODELS FEATURE

AutoSense™ Technology

Monitors your water usage to determine the optimal frequency of regeneration, maximizing efficiency while minimizing salt and water usage.

HE Regeneration

North Star systems use reverse flow during regeneration, proven to be the most effective way to clean a resin bed of hardness minerals.

Reinforced Media Tank

We only use durable, HDPE double-wrapped resin tanks to handle the maximum internal pressures.

NORTH STAR QUALITY



EASY TO INSTALL

North Star systems come with fittings needed for a simple installation.



LOW MAINTENANCE

We incorporate high-efficiency technology and pro-grade materials into our North Star systems, delivering an easy-to-use solution you can count on.



WARRANTY PROTECTION

North Star Water Treatment Systems boast the most comprehensive warranties in plumbing wholesale, proof of our commitment to quality.



HIGH QUALITY MANUFACTURING

Our three U.S. based manufacturing facilities produce 95% of all components in our systems, allowing us to maintain strict control over the quality of our finished products.



UNPARALLELED SUPPORT

Our sales and business development team continually works with you to maximize your water treatment potential.

WANT TO **KNOW MORE?**

If you need more information about North Star Residential Softener Systems, get in touch with us or contact your local North Star representative.

Place Business
Card Here

HOW TO **CONTACT US**

info@northstarwater.com | www.northstarwater.com

NORTH STAR ALSO OFFERS A COMPREHENSIVE LINE OF
RESIDENTIAL FILTRATION & COMMERCIAL PRODUCTS

